



REVA INDUSTRIES LIMITED

Regd. Office & Unit - I :
Plot No. 28, Sector 25, Faridabad - 121 004, Haryana
Phone : + 91 - 129 - 4185400 • Fax : + 91 - 129 - 4185414
Email : reva@revacrane.com • Web : www.revacrane.com
GSTIN : 06AAACR0725N1ZE



An ISO 9001-2008 Company

JIB Crane - Enquiry Form

Capacity Main Hoist (MH) in T * :	
Lifting Height in M * :	
Type of Jib Crane * : Pillar Jib Crane (floor mounted, wall mounted, wall travelling)	
Length of Jib (boom length) *M :	
Pillar Height *M :	
Class of Duty * : 1/2/3/4	
Location of Crane * : Indoor/Outdoor/both [select one] :	
Speeds [leave blank to consider Reva Standard speeds] :	
Lifting Speed MH in MPM :	
Cross Travel Speed in MPM :	
Slew speed in RPM {mention 0 in case not applicable} :	
Creep Speed Requirement {pony motors in hoist are not recommended and feasible}	
VVVF Requirement in MH : Yes / No	
VVVF Requirement in CT : Yes / No	
VVVF Requirement in Slew : Yes / No	
Area of usage : Normal Area / Hot Metal Handling / Hazardous Area / Seismic Zone / Sub Zero temperature / High temperature (above 50 Degree C) / High Moisture Area / Area near Sea [select multiple or single]	
Display Electronic Load by Load cells : Yes/No	
Additional Gravity (counter weight type) Limit Switches	
Any other Special Requirement :	
Special painting if required:	



REVA INDUSTRIES LIMITED

Regd. Office & Unit - I :
 Plot No. 28, Sector 25, Faridabad - 121 004, Haryana
 Phone : + 91 - 129 - 4185400 • Fax : + 91 - 129 - 4185414
 Email : reva@revacrane.com • Web : www.revacrane.com
 GSTIN : 06AAACR0725N1ZE



An ISO 9001-2008 Company

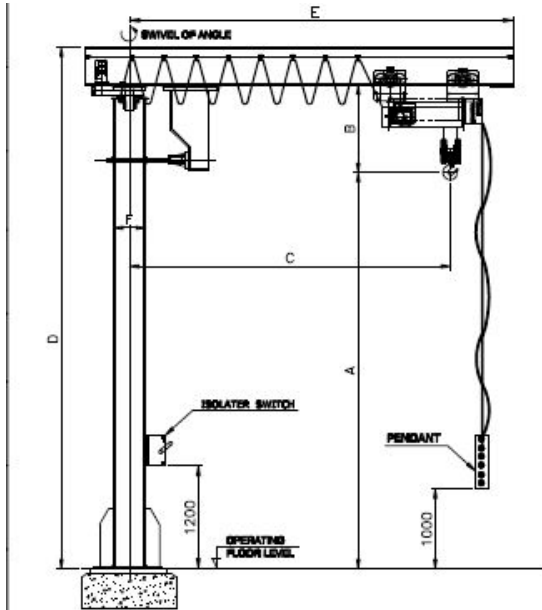

FOR REFERENCE

S.NO.	DESCRIPTION	CODE	DIMENSIONS
7	POST/PILLAR DIA	F	
6	BOOM LENGTH	E	
5	HEIGHT OF UPTO TOP OF CRANE	D	
4	HOOK APPROACH FROM POST/PILLAR CENTRE	C	
3	HOIST HEADROOM	B	
2	LIFT OF HOOK ABOVE FLOOR LEVEL (MH)	A	
1	CAPACITY		

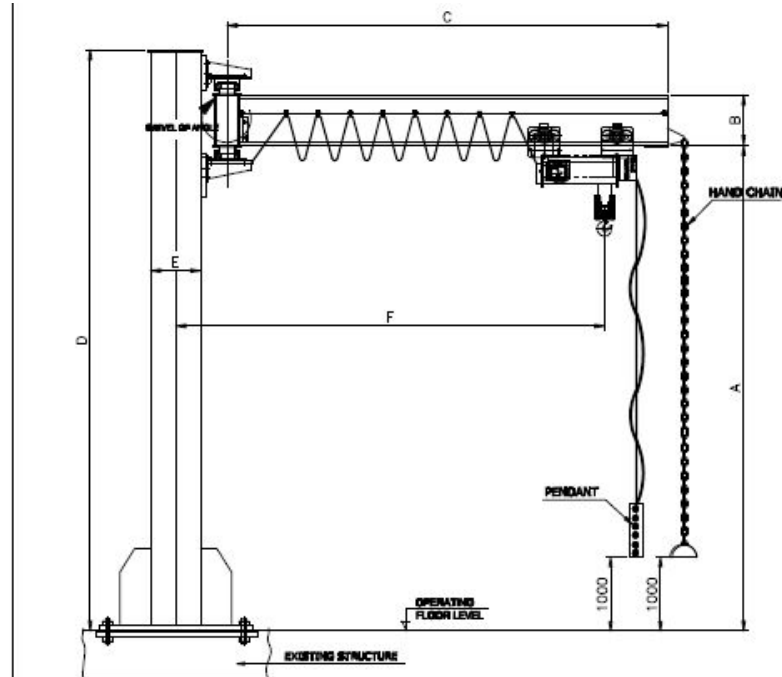

FOR REFERENCE

S.NO.	DESCRIPTION	CODE	DIMENSIONS
7	HOOK APPROACH FROM POST/PILLAR CENTRE	F	
6	POST/PILLAR DIA	E	
5	HEIGHT OF UPTO TOP OF CRANE	D	
4	BOOM LENGTH	C	
3	HOIST HEADROOM	B	
2	LIFT OF HOOK ABOVE FLOOR LEVEL (MH)	A	
1	CAPACITY		